

**THE STRATEGY ON DECENTRALISED POWER STATIONS:  
THE POTENTIAL OF BIOMASS IN LIBERALISED GRIDS**

Jürgen Schmid

Institut für Solare Energieversorgungstechnik (ISET e.V.), Königstor 59, D-34119 Kassel, Germany  
Tel.: +49 (0) 561 7294-345, Fax: +49 (0) 561 7294-300, E-mail: jschmid@iset.uni-kassel.de  
Internet: www.iset.uni-kassel.de

Bernd Krautkremer

Institut für Solare Energieversorgungstechnik (ISET e.V.), Rodenbacher Chaussee 6, D-63457 Hanau, Germany  
Tel.: +49 (0) 6181 58-2707, Fax: +49 (0) 6181 58-2702, E-mail: bkrautkremer@iset.uni-kassel.de

Giuliano Grassi

European Biomass Industry Association – EUBIA, Rond-Point Schumann 6, B - 1040 Brussels, Belgium  
Tel: +32 2 28 28 420, Fax: +32 2 28 28 424, E-mail: eubia@eubia.org, Internet: www.eubia.org

**ABSTRACT:** There is an increasing acceptance of the use of renewable energy sources to achieve a sustainable power supply. Different opinions exist mainly as to what extent the different renewable energy sources can provide energy and how the boundary conditions for their growth should be implemented. New supply structures will emerge, which distinguish themselves by decentralised i.e. consumer-oriented generation. The trade in electric power is increasingly characterised by mechanisms that are known from other sectors of the market economy.

Fuels from biomass can be derived through various processes, resulting in varying characteristics. This causes problems with the combined heat and power (CHP) processes because of the narrow range of selection of acceptable fuel quality. On the other hand CHP systems often suffer from the lack of sensible usage of the heat. Gas turbines can be operated with a wide variety of fuels with varying heat contents. The excess heat is available in only one medium (the exhaust gas) at high temperature, which allows the implementation of a multitude of processes like steam production, preheating or chilling processes.

**1 RENEWABLE ENERGY SOURCES, DECENTRALISED COMBINED HEAT AND POWER AND NEW ENERGY SUPPLY STRUCTURES**

There is an increasing acceptance of the use of renewable energy sources to achieve sustainable electric power supply. Different opinions exist mainly as to what extent the different renewable energy sources can provide energy and how the boundary conditions for their growth should be implemented. Whereas the sustainability with regard to the ecological tolerance is recognised to a large extent, the possibilities for further development of the techniques for the use of renewable energies as well as the social acceptance of these technologies will determine to what extent the big national and worldwide potentials of renewable energy sources can be exploited.

Hereby, new supply structures will emerge, which distinguish themselves by decentralised, i.e. consumer-oriented, generation. The trade in electric power is increasingly characterised by mechanisms that are known from other sectors of the market economy. The further development of the use of local resources for instance wind, solar, biomass etc., is particularly relevant in this context together with the reliability of the power supply through the complementing of various, differently fluctuating energies on different grid levels, storable energy sources like biomass and energy transmission via long distances (extension of the public grid) from regions with particularly high energy yields.

At the same time it is necessary to use the fossil fuels as efficiently as possible. The heating demand in buildings can for instance be reduced to the average electrical power demand level using available technologies. In contrast to the conventional separate generation of heating at the location of consumption and the generation of electric power in central power plants, the expansion of the decentralised combined heat and power (CHP) would save approximately one third of the

fossil fuels.

One of the most important tasks for the new future energy supply structures will be an effective interaction at all involved levels (generation, transmission, distribution, consumption). Beside the particularly fast developing electronic communication networks, powerful and flexible concepts for energy, grid and cost management are of importance.

**Figure 1: Decentralised combined heat and power**

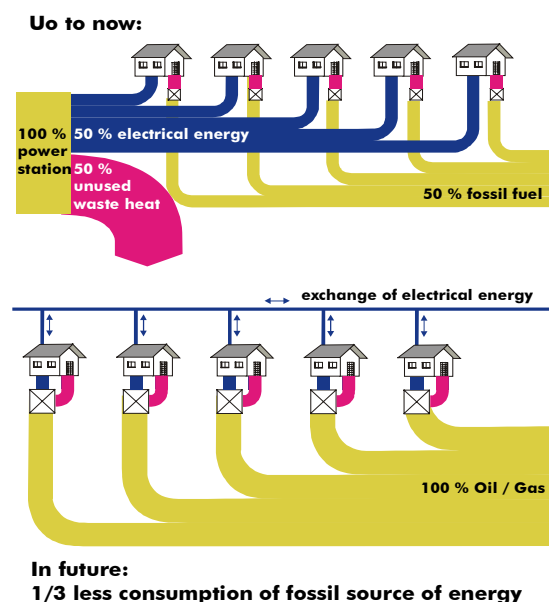

## 2 ENERGY AND COST MANAGEMENT

Experiences from Great Britain and some Scandinavian countries have shown that through the liberalisation of the energy market, energy prices have rapidly fallen and that enormous price fluctuations at the energy stock markets are possible. However, this is not in fundamental conflict with the rational energy use, but offers a chance for use of the newly gained flexibility to a decentralised efficient generation of electrical power in dependency on the market. [4]

More diversified and time-variable tariffs in combination with automated and standardised communication networks between the supplier and the consumer offers new possibilities of the load flow regulation. This is particularly attractive for big complex consumers such as industrial plants, who possibly operate their own generation units, as for example CHP plants for the process steam production.

A power pool between the energy distributor and the clients can be described in a basic approach as a spot market of a local energy stock market. Supply and demand determine the variable energy price for which, for instance, in hourly units supply agreements are made. The price is fixed within a time frame and certain load fluctuations are tolerated, while a level energy balance is strived for at the end of the time frame. [4]

The client obtains the chance to optimise the energy supply or alternatively, energy injections according to his own criteria and conditions for instance the demand situation. Sudden load drops or load restrictions caused by the supplier could be avoided. Huge inevitable power reserves on the generation side could be reduced.

Positive experiences have been made with variable power tariffs in the supply of typical household customers in a model project in the city of Eckernförde [8]. Via centralised ripple control signals and a nine-level current value „traffic light“ the customers received relative price information. The projections of the changed user behaviour of the one thousand randomly selected test households to the whole city area showed distinct load variations in the daily and weekly trends from the peak load periods to the low load periods. The main peak load was decreased to a maximum of about 6 % in winter and to a maximum of 5 % in summer.

The aim of the European project “Building Energy Management with Smart Systems (BySyS)” [7] was to develop a load management system that allows maximum user control possibility. In order to achieve this, two currently used grids have been connected to each other: the European Installation Bus (EIB) building automation and the TCP/IP network (internet). With this, the user has the possibility to set his own options for energy management at his work place via an internet-based dialogue on an EIB installation with the option to operate manually via the EIB-switch. [7]

## 3 DECENTRALISED POWER QUALITY AND GRID MANAGEMENT

Innovative energy conversion technologies like variable speed mechanical-electrical converters for wind and hydro-power plants, combustion units and micro-

turbines as well as direct converters, such as solar and fuel cells, batteries and flywheel storages are connected via inverters to the power grid. The rapid development in power electronics and microcomputer technology has in the last few years led to considerable cost decreases with simultaneous increase in efficiency. In addition, further possibilities in power conditioning were established.

Thanks to modern inverters, it is not only possible to generate sinusoidal voltages and sinusoidal current with synchronous phases (active power), but also to compensate for reactive power and harmonics. The capability of such equipment is determined by the chosen circuits topologies, the employed devices as well as the control concepts. Conventionally, grid-coupled inverters generate the output current and frequency from a grid voltage signal. The power feed-in is regulated from the inverter. For integration into superior network regulation systems, corresponding communication links are necessary.

If suitable new control procedures are implemented in the inverters [5], they can be operated as parallel voltage sources in the grid. As it is common with conventional power generators in the grid, the power contributions of the plants are regulated through static curves. The frequency determines the active power and the voltage the reactive power. Furthermore, inverters with new control procedures can guarantee the uninterruptible operating of the inverter in case of a power failure of the grid. Accordingly, the existing storage elements in the inverter i.e. connected storages UPS (uninterruptible power supply) features can be realised.[5]

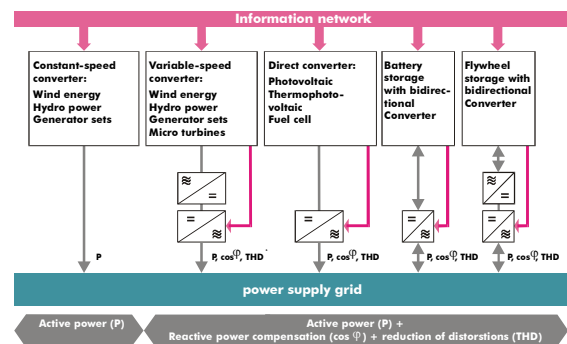

**Figure 2:** Decentralised management of power supply systems

Besides exact information concerning the statistical behaviour of fed-in wind power, the forecast of expected short to medium-term power feed-in is important for the generation schedule and load management. Network operators of major energy supply utilities and electricity transmission companies currently make use of Artificial Neural Networks (ANN) and numerical weather forecasts to predict the generation schedules of power stations and loads.

The capability of ANN in predicting wind power output has been thoroughly examined by several institutes. Their advantages, compared to other computing procedures, are that they can both 'learn' from experience, and 'guess' or interpolate results, even

when their inputs are contradictory or incomplete. In cooperation with the E.ON Netz GmbH, Lahmeyer International GmbH and the Förlergemeinschaft Windenergie, ISET developed a new wind power prediction model. This model is based on a combination of four proven approaches:

- accurate prediction of wind speed and direction for selected locations provided by the "Deutsche Wetterdienst (DWD)"
- transformation of predicted wind data to the wind farm locations using the atmospheric model KLIMM
- determination of the accessory wind turbine power output, using ANNs
- extrapolation of the predicted power on the total power input in the selected supply area with ISET's online-model

The prognosis model is based on a selection of representative wind farm groups, equipped with wind and power measurement. The model is trained, using past wind and power data, to recognise the relationships between variations in the wind and the power output of the wind turbines. For these locations, the DWD provides wind fore-casts for a 72 hour period. The predicted wind speed and direction are permanently compared with observed wind data and general deviations are adjusted. The atmospheric model KLIMM transforms this data for individual wind farms. In addition to the predicted wind data, the wind power that was collected online is used as input value for the model to improve the short-term forecast (up to 4 hours).

These trained networks compute the predicted wind power output of the representative wind farms, which is used as input for the online model. The online model enables a prediction of the total wind power feed-in of large utility supply areas, using only a few locations with predicted wind speed. Based on these models, short-term prediction (from 1 to 48 hours) is another important step towards improved integration of wind energy into the system demand control and generation schedule of utility companies with a high share of wind energy. As the model for the online monitoring and prediction of great wind capacity can be adapted to various supply systems, it is particularly important for various electricity utilities in order to improve the grid integration of their wind capacities.

#### 4 MIKRO TURBINES FOR THE CONVERSION OF BIOGAS

Since the energy content of biomass is quite low, the transportation ways have to be relatively short, which requires the implementation of small, decentralised plants. This decentralised structure gives the opportunity to use the excess heat for further applications.

Most of the common small power output CHP processes require liquid or gaseous fuels. The fuels can be derived from biomass through various processes resulting in different fuels with varying characteristics. This causes problems with the CHP processes because of the narrow range of selection of acceptable fuel quality. On the other hand CHP systems often suffer from the lack of sensible heat usage. Both problems can be solved by using gas turbines, which can be operated with a wide

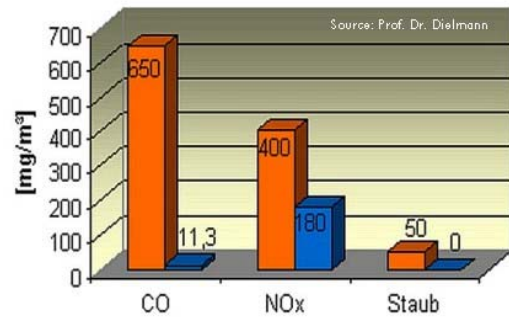

Figure 3: Exhaust emissions of micro turbines are very low compared to the German limits

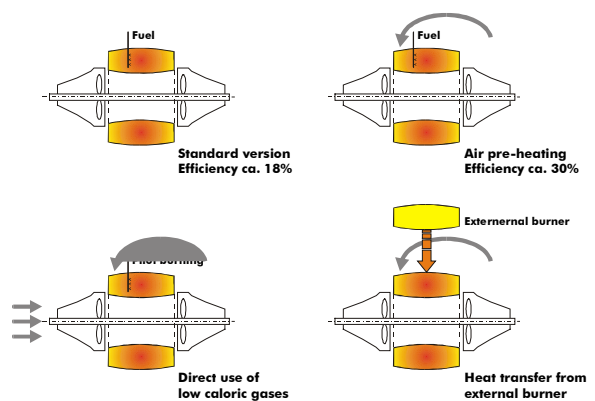

Figure 4: Different possibilities for conversion of biogas with micro turbines



Figure 5: Micro turbine in the ISET's R&D center

variety of fuels with varying heat contents. The excess heat from the process is available in only one medium (the exhaust gas) at high temperature, which allows the implementation of a multitude of processes like steam production, preheating or chilling processes.

In the past, gas turbines were only available for huge power output. New developments in the field of turbochargers, recuperators and power electronics made the production of gas turbines, which provide sufficient efficiency even with small power output, possible. This allows the use of this technique also in small, decentralised plants, which will dominate in the use of biomass.

There is no exact definition for micro turbines, but some essential technical details are common for all machines of this type:

- Electrical power output of about 100kW or less
- Simple design with generator, compressor and turbine on one shaft; no gearbox
- Compressor pressure ratio
- Turbine inlet temperatures under 1200K
- Recuperator

These design features result in very low maintenance costs that make this type of engine very attractive for the decentralised energy conversion.

Decreasing the size of biogas plants to a suitable degree in the agricultural surrounding will result in stronger variations in the heat content of the fuel. Conventional piston machines will only be able to operate under these circumstances if complex control techniques are applied. This prevents an economic success whereas the problem can be easily solved by using micro turbines, as they will still operate with methane contents of about 30%.

## 5 SUMMARY AND OUTLOOK

The extension of the use of renewable energy as well as the decentralised CHP stimulates a steady growth of decentralised power producers in the power supply grid. Generation units that feed-in power into the grid through modern inverters can generally also compensate reactive power and reduce distortions, thereby improving the grid power quality. Inverter control procedures with frequency/active power statics and voltage/reactive power statics improve the supply reliability and enable to participate decentralised units on transients in the grid.

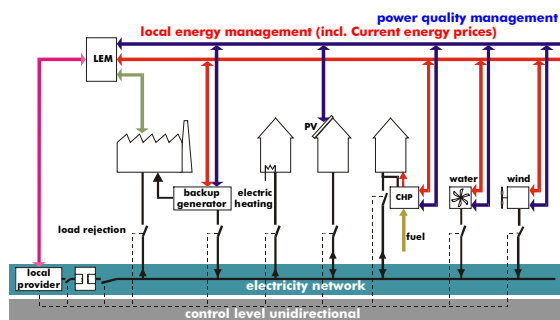

Figure 6: Energy and power quality management

The aim of the future R&D efforts should be to construct the transforming power supply structures such that the grid stability and the supply reliability is possible without availability of large power reserves even with a rising number of fluctuating producers. Therefore the storable biomass will have a special significance for the future power supply.

Apart from the right mixture of energy sources, efficient communication structures, online- and prognosis procedures for the grid operating plan as well as bi-directional power management and marketing systems for the dialogue between the power producer, distributor and consumer are of special significance.

## 6 REFERENCES

- [1] J. Schmid, W. Kleinkauf, M. Hoppe-Kilpper, M. Durstewitz, U. Krengel: Der Beitrag erneuerbarer Energien in zukünftigen elektrischen Versorgungssystemen, Energiezukunft 2030 - Schlüsseltechnologien und Techniklinien, in: Tagungsband IKARUS-Workshop der FfE, Mai 2000, Schliersee
- [2] G. Czisch, C. Ensslin, M. Hoppe-Kilpper, K. Rohrig, B. Emonts, W. Kleinkauf, F. Trieb, F. Staiss: Aufbau von Versorgungsstrukturen mit hohem Anteil Erneuerbarer Energien, Integration erneuerbarer Energien und dezentrale Energieversorgung, in: Tagungsband Jahrestagung ForschungsVerbund Sonnenenergie, September 2001, Potsdam
- [3] E. Engler, U. Krengel, K. Rohrig, J. Schmid (ISET); W. Kleinkauf, P. Otto (GhK); T. Stephanblome (EUS): Jahrestagung ForschungsVerbund Sonnenenergie, Integration Erneuerbarer Energien in Versorgungsstrukturen, 20.-21. September 2001, Potsdam
- [4] P. Otto: Bidirektionales Energiemanagement zwischen Stromversorger und Kunden mit Hilfe eines dynamischen Preismodells im liberalisierten Energiemarkt, Interne Studie, Fachgebiet Rationelle Energiewandlung, Institut für Elektrische Energietechnik, Universität Gesamthochschule Kassel, 1999, Kassel
- [5] A. Engler: Stromrichter für modular erweiterbare dezentrale elektrische Versorgungen - USV mit höchsten Anforderungen, VDI Gesellschaft Energietechnik in: Tagungsband Fachtagung, November 2001, Braunschweig
- [6] K. Rohrig, D. Christoffers: Prognoseverfahren zur optimalen Nutzung erneuerbarer Energien, in: Tagungsband Jahrestagung ForschungsVerbund Sonnenenergie, September 2001, Potsdam
- [7] I. Stadler: Dialogfähige Energiemanagementsysteme im Kontext von Energieverbrauch und Nutzerverhalten, Dissertation, Universität Gesamthochschule Kassel, April 2001, Kassel
- [8] T. Morovic, R. Pilhar, W. Möhring-Hüser: Dynamische Stromtarife und Lastmanagement - Erfahrungen und Perspektiven, in: Tagungsband Kasseler Symposium Energie-Systemtechnik '97, Oktober 1997, Kassel
- [9] B. Krautkremer, Neue Energiewandlungstechnologien, Entwicklungsstand und Ausblick., ASEW-Seminar "KWK und Brennstoffzelle - Sachstand und Perspektiven", Februar 2002 Bielefeld
- [10] Dielmann, Klaus P., "Mikrogasturbinen, Technik und Anwendung," BWK Das Energiemagazin, 2001, 6 - 11